

Dynacorp

100 Franklin Drive
Torrington, CT 06790
Toll Free Phone 800-800-6445
Phone 860-482-4444 Fax 860-482-4378
Email: sales@idicb.com

D2750 Clutch Brake Control Instructions

P/N 214257-040-2230 - Logic Input: 120 VAC
P/N 214257-040-2231 – Logic Input: 3 to 32 VDC
P/N 214257-040-2232 – Logic Input: Contact Closure

Features:

- Adjustable soft start / stop
- Provides power directly to the clutch/brake. No interfacing relay needed (less wiring)
- Fast response time for high-speed machines
- Compact size – only 10.8 square inches of panel space (DIN rail or panel mount)
- Flexible, versatile control interface (PLC compatible)
- Increases clutch/brake life with adjustable Anti-Overlap switching time delay
- Status indicator for each load

D2750 is an all-solid-state power supply relay for 90 VDC magnetic clutches and brakes with the ability to operate clutches and brakes at high speeds with less mechanical wear. Soft starting and stopping is controlled with ramp time (ramp time adjustable from 0 to 2 seconds). Three input logic options allow interface with PLC's, photoelectric controls, proximity sensors, contacts, transistors, etc. If the clutch or brake current rises above a preset level, an overload protection circuit turns the clutch and brake off to protect the output switches. Power must be removed and reapplied to reset the circuit.

OPERATION (see wiring diagrams):

P/N 214257-040-2230 and 214257-040-2231

- a. When power is applied to L1, L2 with no logic voltage present, the brake energizes.
- b. When logic voltage is applied to terminals 1, 2 brake immediately de-energizes. Clutch is energized following preset Switching Time Delay.
- c. When logic voltage is removed, clutch de-energizes and, following Switching Time Delay, brake energizes.

P/N 214257-040-2232

Maintained 3-wire (1 SPDT switch)

- a. When power is applied to L1, L2 with 2, 3 contacts closed, brake energizes.
- b. When 2, 3 contacts open and 1, 3 contacts close, brake de-energizes, Clutch is energized following preset Switching Time Delay.
- c. When 1, 3 contacts open and 2, 3 contacts close, clutch de-energizes and, following Switching Time Delay, brake energizes.

Maintained 2-wire (1 SPST switch)

- a. When power is applied to L1, L2 with 1, 3 contacts open, brake energizes.
- b. Maintained closure of 1, 3 contacts causes brake to de-energize. Clutch is energized following preset Switching Time Delay.
- c. When 1, 3 contacts open, clutch de-energizes and, following Switching Time Delay, brake energizes.

Momentary (2 SPST switches)

- a. When power is applied to L1, L2 with 1, 3 and 2, 3 contacts open, brake energizes.
- b. Momentary closure of 1, 3 contacts causes brake to de-energize. Clutch is energized following a preset Switching Time Delay.
- c. Momentary closure of 2, 3 contacts causes clutch to de-energize. Brake is energized following a preset Switching Time Delay.
- d. With 1, 3 and 2, 3 contacts closed, 1, 3 contacts override and clutch energizes.

Notes:

Logic terminals 1, 2 on the 214257-040-2230 and 214257-040-2231 are isolated. Terminal L2 and/or 2 may be grounded. Logic terminals 1, 2, 3 on the 214257-040-2232 are not isolated and must not be grounded. Load terminals (A – B - C) and terminal 3 are not isolated from line terminals (L1, L2), and must not be connected to ground or the ground side of a line. Do not place switches or mechanical contacts between clutch and brake and their terminals (A – B - C). Opening these circuits while current is flowing may damage the control.

All Models
Input Voltage: 120 VAC
Output Current: 1.0 Amps Max

Switching Time Delay

Switching time is a delay between clutch power off and brake power on, and vice versa. By adjusting this delay, you can obtain the fastest cycling time and the least wear on your system. If a clutch/brake control switches too quickly, there may be a mechanical overlap between the clutch and the brake. The D2750 is supplied with an 8.2 Kilo-ohm resistor, which provides a 82 ms switching time delay. Since smaller clutch & brakes respond faster, the switching time delay resistor can be changed. A jumper may be installed in the place of the resistor to obtain the shortest switching time delay. Switching time delay relates to resistor size as follows:

$$T_s = R \times 10$$

R = Switching Time Delay resistor, in Kilo-ohms.

T_s = Switching Time Delay, in milliseconds

Table 1 - Typical Clutch/Brake Data (at room temperature)

Size (in)	Torque (ft-lb)	Coil data		Flux Rise Time (msec)	Suggested Switching Time Delay (ohms)
		Res. (ohms)	Current (amps)		
2 5/8	5/8	1150/800	.11/.09	50	2.7 K
4 1/4	20/22	820/700	.13	60	3.3 K
5 5/8	50/57	270/220	.41/.39	90	3.3 K
8 1/2	125/175	225/160	.57/.47	180	8.2 K
12 1/4	465/525	260/245	.43/.34	350	12 or 15 K
15 1/4	700/850	305/220	.41/.34	510	18 or 22 K

Notes:

- Flux rise time is the typical time for flux to build up to 90% of the steady state value. This point is typically equal to 80% of rated torque.
- Flux decay time to 10% of steady state flux using the D2750 is typically 20% to 30% of the flux rise time.
- Flux rise time is independent of switching time delay.

Specifications	P/N 214257-040-2230	P/N 214257-040-2231	P/N 214257-040-2232
Line Input (L1, L2 terminals)	120 VAC +/- 20%, 50/60 Hz, 25 mA burden (excluding load current)		
Logic Input (1,2 terminals)	120 VAC +/- 20%, 50/60 Hz, 25 mA burden (will not operate on leakage current below 10 mA)	3-32 VDC, 1-35 mA burden	contact closure; contacts must be able to switch 12 VDC, 1 mA
Logic Response Time (excluding Switching Time Delay)	1-9 msec	< 1 msec	< 1 msec
Load Rating (A - B - C terminals) Steady-state output Current Rating	105 VDC at 120 VAC line input 1.0 Amps maximum		
Ramp Time	adjustable, 0 to 2 seconds (+/- 20%)		
Switching Time Delay	adjustable from less than 1 msec to 100 msec		
Recommended Line Fuse (L1 terminal)	Wickmann 19230/19231 2A or Buss KAA1		
Temperature	0 to 65° C (32 to 149° F)		

WARNING: Because of the possible danger to person(s) or property from accidents, which may result from the improper use of products, it is important that correct procedures be followed: Products must be used in accordance with the engineering information specified in the catalog. Proper installation, maintenance and operation procedures must be observed. The instructions in the instruction manuals must be followed. Inspections should be made as necessary to assure safe operation under prevailing conditions. Proper guards and other suitable safety devices or procedures as may be desirable or as may be specified in safety codes should be provided, and are neither provided by Dynacorp nor are the responsibility of Dynacorp.

WIRING DIAGRAMS

214257-040-2230

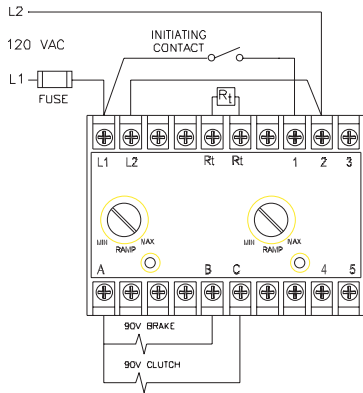

214257-040-2231

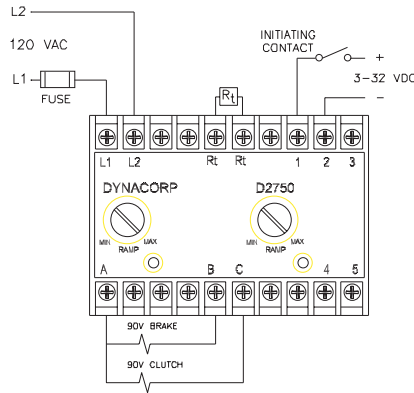

214257-040-2232

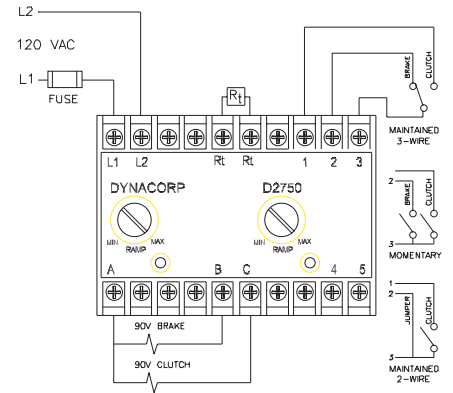

DIMENSIONS $\frac{\text{in}}$ (mm)

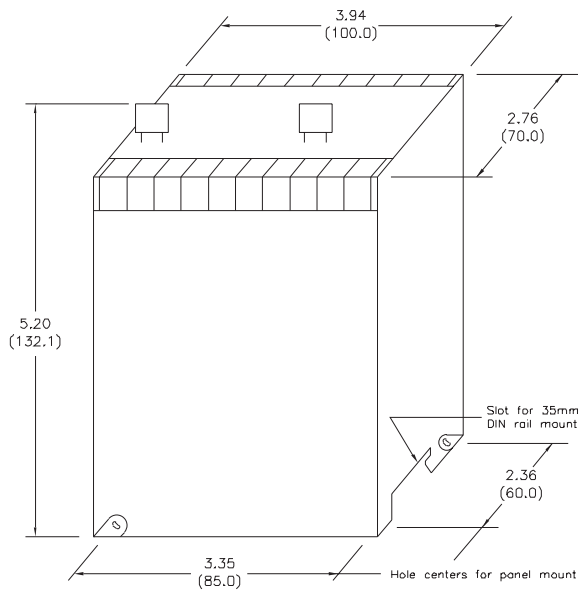

Note: Optional terminal covers are available.

TIMING DIAGRAM

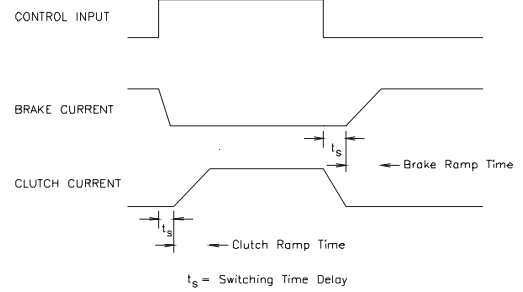

D2750