

Dynacorp

100 Franklin Drive
Torrington, CT 06790
Toll Free Phone 800-800-6445
Phone 860-482-4444 Fax 860-482-4378
Email: sales@idicb.com

Features:

- Provides power directly to the clutch/brake. No interfacing relay needed (less wiring)
- Fast response time for high-speed machines
- Compact size – only 5.4 square inches of panel space (DIN rail or panel mount)
- Flexible, versatile control interface (PLC compatible)
- Increases clutch/brake life with adjustable Anti-Overlap switching time delay
- Status indicator for each load

The **D2550** is an all-solid-state power supply relay for 90 VDC magnetic clutches and brakes. Advanced features offer the ability to operate clutches and brakes at very high speeds, with less mechanical wear. Three different input logic options allow interface with PLC output modules, photoelectric controls, proximity sensors, contacts, transistors, etc. The Adjustable Switching Time Delay feature will minimize the overlap between alternate starting and stopping for longer life.

OPERATION (see wiring diagrams):

P/N 214247-040-2201 and 214247-040-2202

- a. When power is applied to L1, L2 with no logic voltage present, the brake energizes.
- b. When logic voltage is applied to terminals 1,2 brake immediately de-energizes. Clutch is energized following preset Switching Time Delay.
- c. When logic voltage is removed, clutch de-energizes and, following Switching Time Delay, brake energizes.

P/N 214247-040-2203

Maintained 3-wire (1 SPDT switch)

- a. When power is applied to L1, L2 with 2,3 contacts closed, brake energizes.
- b. When 2, 3 contacts open and 1, 3 contacts close, brake de-energizes, Clutch is energized following preset Switching Time Delay.
- c. When 1, 3 contacts open and 2, 3 contacts close, clutch de-energizes and, following Switching Time Delay, brake energizes.

Maintained 2-wire (1 SPST switch)

- a. When power is applied to L1, L2 with 1, 3 contacts open, brake energizes.
- b. Maintained closure of 1,3 contacts causes brake to de-energize. Clutch is energized following preset Switching Time Delay.
- c. When 1, 3 contacts open, clutch de-energizes and, following Switching Time Delay, brake energizes.

D2550 Clutch Brake Control Instructions

P/N 214247-040-2201 - Logic Input: 120 VAC

P/N 214247-040-2202 - Logic Input: 3 to 32 VDC

P/N 214247-040-2203 - Logic Input: Contact Closure

P/N 214247-040-2203 continued

Momentary (2 SPST switches)

- a. When power is applied to L1, L2 with 1, 3 and 2, 3 contacts open, brake energizes.
- b. Momentary closure of 1, 3 contacts causes brake to de-energize. Clutch is energized following a preset Switching Time Delay.
- c. Momentary closure of 2, 3 contacts causes clutch to de-energize. Brake is energized following a preset Switching Time Delay.
- d. With 1, 3 and 2, 3 contacts closed, 1, 3 contacts override and clutch energizes.

Notes:

1. Logic terminals 1, 2 on the 214247-040-2201 and 214247-040-2202 are isolated. Terminal L2 and/or 2 may be grounded. Logic terminals 1, 2, 3 on the 214247-040-2203 are not isolated and must not be grounded.
2. Load terminals (A – B - C) and terminal 3 are not isolated from line terminals (L1, L2), and must not be connected to ground or the ground side of a line.
3. Do not place switches or mechanical contacts between clutch and brake and their terminals (A – B - C). Opening these circuits while current is flowing may damage the control.

Switching Time Delay

The Dynacorp D2550 features adjustable switching time delay. Switching time is a delay between clutch turn-off and brake turn-on, and vice versa. By adjusting this delay, you can obtain the fastest cycling time and the least wear on your system. If a clutch/brake control switches too quickly, there may be a mechanical overlap between the clutch and the brake (the clutch and brake will work against each other). The switching time delay feature can reduce or eliminate this overlap and increase the useful life of the clutch and brake. The D2550 is supplied with an 8.2 Kilo-ohm resistor, which provides a 82 ms switching time delay. Since smaller clutch/brakes tend to respond faster, the switching time delay resistor can be reduced in many applications (see table1). A jumper may be installed in the place of the resistor to obtain the shortest switching time delay. Switching time delay relates to resistor size as follows:

$$T_s = R \times 10$$

R = Switching Time Delay resistor, in Kilo-ohms.

All Models
Input Voltage: 120 VAC
Output Current 1.0 Amps Max

T_s = Switching Time Delay, in milliseconds

Size (in)	Torque (ft-lb)	Coil data		Flux Rise Time (msec)	Suggested Switching Time Delay (ohms)
		Res. (ohms)	Current (amps)		
2 5/8	5/8	1150/800	.11/.09	50	2.7 K
4 1/4	20/22	820/700	.13	60	3.3 K
5 5/8	50/57	270/220	.41/.39	90	3.3 K
8 1/2	125/175	225/160	.57/.47	180	8.2 K
12 1/4	465/525	260/245	.43/.34	350	12 or 15 K
15 1/4	700/850	305/220	.41/.34	510	18 or 22 K

Notes:

- Flux rise time is the typical time for flux to build up to 90% of the steady state value. This point is typically equal to 80% of rated torque.
- Flux decay time to 10% of steady state flux using the D2550 is typically 20% to 30% of the flux rise time.
- Flux rise time is independent of switching time delay.

Specifications	P/N 214247-040-2201	P/N 214247-040-2202	P/N 214247-040-2203
Line Input (L1, L2 terminals)	120 VAC +/- 20%, 50/60 Hz, 25 mA burden (excluding load current)		
Logic Input (1,2 terminals)	120 VAC +/- 20%, 50/60 Hz, 25 mA burden (will not operate on leakage current below 10 mA)	3-32 VDC, 1-35 mA burden	contact closure; contacts must be able to switch 12 VDC, 1 mA
Logic Response Time (excluding Switching Time Delay)	1-9 msec	< 1 msec	< 1 msec
Load Rating (A,B,C terminals) Steady-state output Current Rating Recommended Load Fuse (A terminal)	105 VDC average at 120 VAC line input 1.0 Amps maximum Buss PCB1		
Switching Time Delay	adjustable from less than 1 msec to 100 msec		
recommended Line Fuse (L1 terminal)	Wickmann 19230/19231 2A or Buss KAA1		
Temperature	0 to 65° C (32 to 149° F)		

WARNING: Because of the possible danger to person(s) or property from accidents, which may result from the improper use of products, it is important that correct procedures be followed: Products must be used in accordance with the engineering information specified in the catalog. Proper installation, maintenance and operation procedures must be observed. The instructions in the instruction manuals must be followed. Inspections should be made as necessary to assure safe operation under prevailing conditions. Proper guards and other suitable safety devices or procedures as may be desirable or as may be specified in safety codes should be provided, and are neither provided by Dynacorp nor are the responsibility of Dynacorp.

D2550 Wiring Diagrams

214247-040-2201
Logic Input: 120 VAC

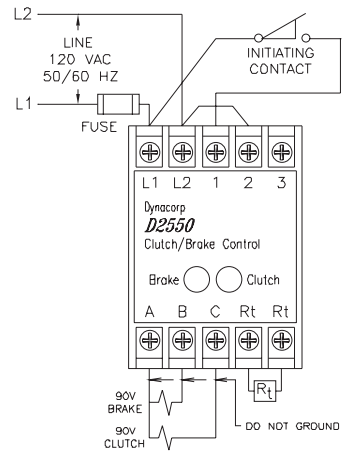

214247-040-2202
Logic Input: 3 to 32 VDC

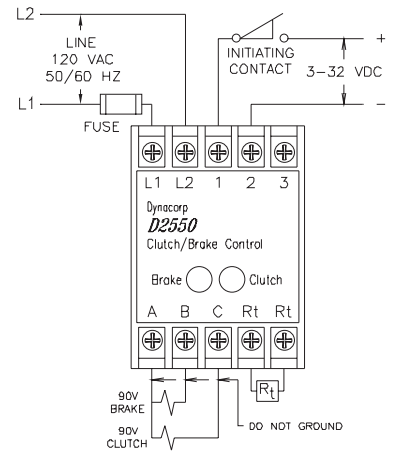

214247-040-2203
Logic Input: Contact Closure

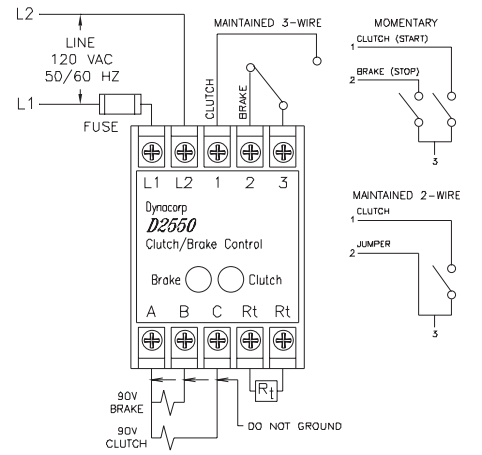

DIMENSIONS $\frac{\text{in}}{\text{(mm)}}$

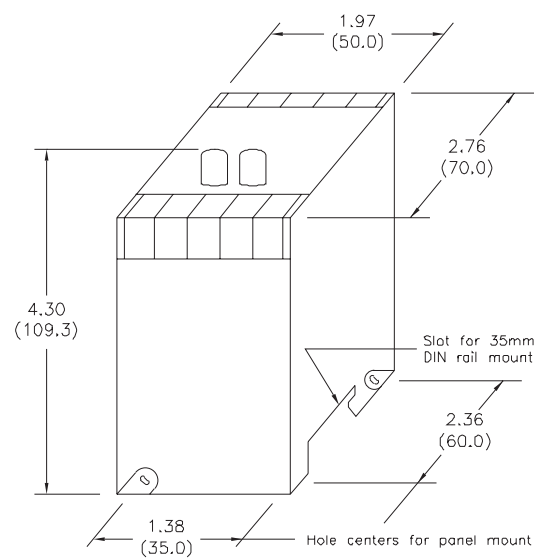

Note: Optional terminal covers are available.

TIMING DIAGRAM

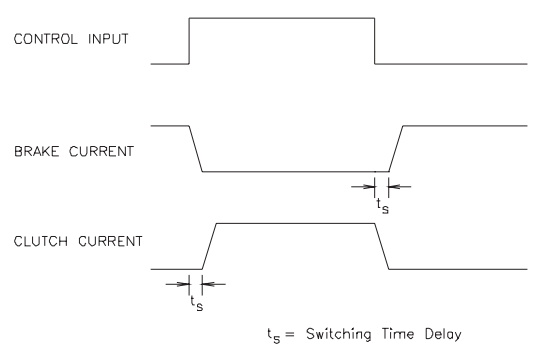

t_s = Switching Time Delay