

Enclosed Housing

Models

- SSBP-145-6
- SSBP-145-10

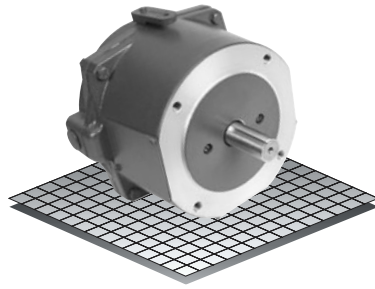

DC Motor Coupler Brakes

- ▶ Factory Assembled and Tested
- ▶ Manual Release
- ▶ DC Power Off
- ▶ Coupler
- ▶ 145TC

DC Coupler Brake

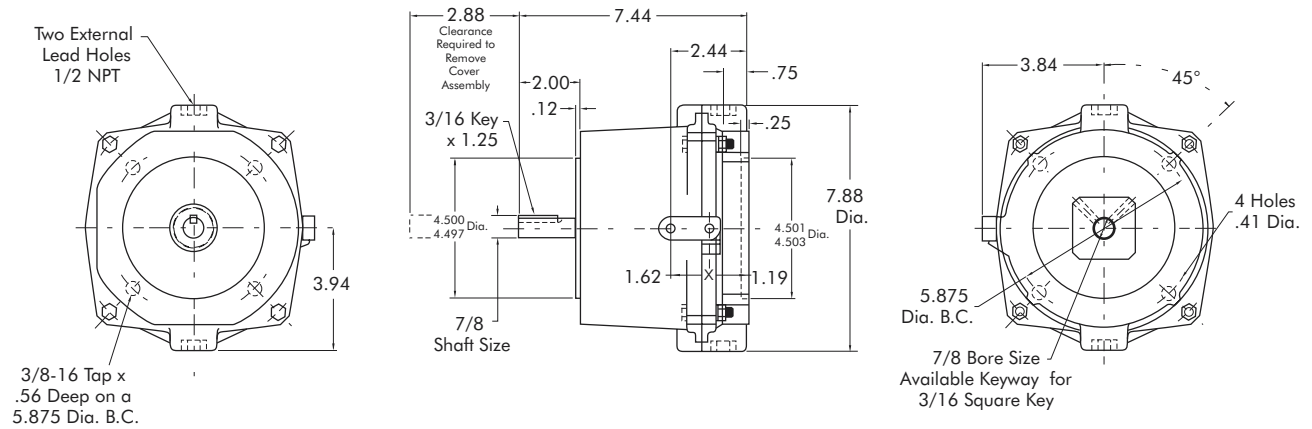

Technical Data and Torque (In. Lb.)

Model No.	Wt. Lbs.	Static Torque In. Lb.	DIRECT CURRENT		
			Voltage	Current Amps	Resistance Ohms
SSBP-145	13	72 or 120	24	.81	29.5
			90	.25	390

	Model No.	
	SSBP-145-6 72 In. Lb. Part No.	SSBP-145-10 120 In. Lb. Part No.
24 VDC	305199-M52C062Y	305199-M53C072Y
90 VDC	305199-M52C062X	305199-M53C072X
Friction Disc Kit	327202	327202-1
24 VDC Solenoid	327208	327208
90 VDC Solenoid	327209	327209

Must be direct-coupled; not recommended for belted or other overhung load applications.